

**B737
MRG**

中文
**B737
MRG**

**A320
MRG**

中文
**A320
MRG**

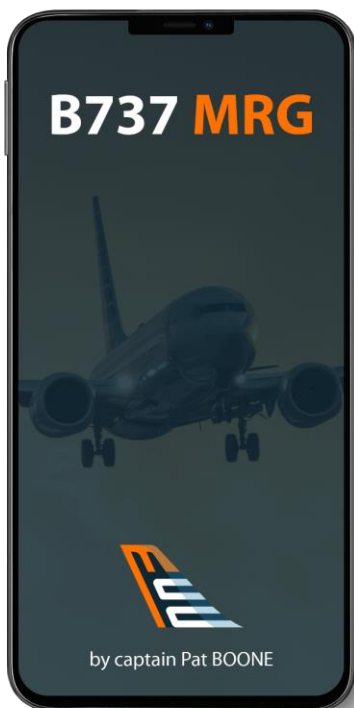

B737MRG PREVIEW

demo 1

The **B737MRG** covers
all QRH non-normals
and many more

| | |
|----------------------------------------------------------------|-------------|
| Toilet / Water System Malfunctions | |
| Airstair Fail | |
| BLEED TRIP OFF | |
| Trim Air Fail | 400-800-900 |
| WING ANTI-ICE VALVE OPEN | |
| MCP Faults | |
| Radio Continuous Transmit (Stuck Microphone Switch) | |
| BAT DISCHARGE | NG |
| TR Failure - DC BUS OFF | |
| EEC ALTERNATE MODE | NG |
| Nitrogen Generator System Fail | |
| LOW IDLE | CL |
| CARGO FIRE DETECTOR FAULT | |
| FSEU Fail | NG |
| Stabilizer Trim Inoperative | |
| CDS MAINT - CDS FAULT | NG |
| Radio Altimeter Fail | |
| IRS / ADIRU Drift | |
| GEAR DISAGREE | |
| PSEU | NG |

demo 2

The **B737MRG** displays
a logic gate for all
amber, green, red and blue
flight deck lights

Loss of DC power on DC BUS 1 / 2 for > 3"

Rate of cabin pressure change > 2.000 ft/min SLE

Cabin altitude above 15,800 feet

Differential pressure > 8.75 PSID

Fault in Outflow Valve Control

Fault in Pressurization Controller 1 / 2

OR

**AUTO
FAIL**

(In FLT) Auto Brake Arm Conditions not met

(On GND) Auto Brake System Deactivated

Antiskid system INOP or OFF

Electric Power Fail (DC BUS 1-2)

Loss of Hydraulic System Pressure

Auto Brake Select Switch not in OFF

OR

AND

**AUTO BRAKE
DISARM**

REV (amber)

One or both Thrust Reverser Sleeve(s) between 10% and 90%

REV (green)

Both Thrust Reverser Sleeves more than 90% to deploy



Two or more Circuit Cards (*1) have failed in either DEU

One Circuit Card (*1) has failed in both DEU

Total failure (*2) of either DEU

N1-N2-EGT miscompare between DEU 1-2

Data Loader Selector in DEU 1 or 2 pos. (*3)

Hot Batt Bus not powered during DEU init. (*3)

OR

**CDS
FAULT**

demo 3

The **B737MRG** displays
a logic gate
for system operation

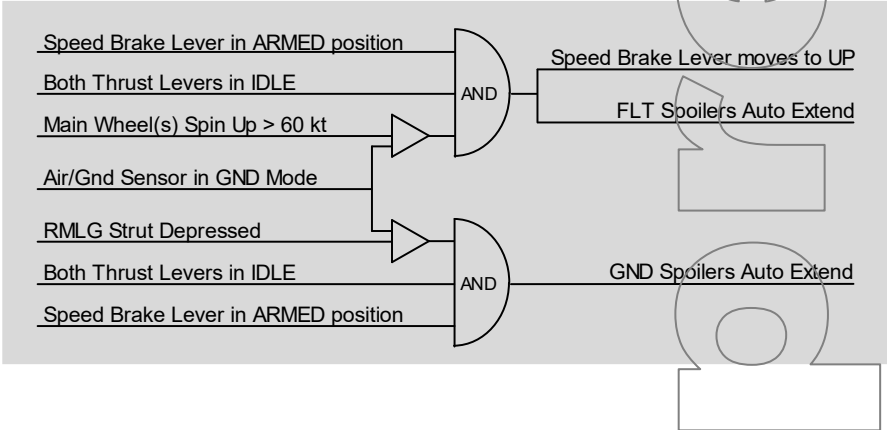
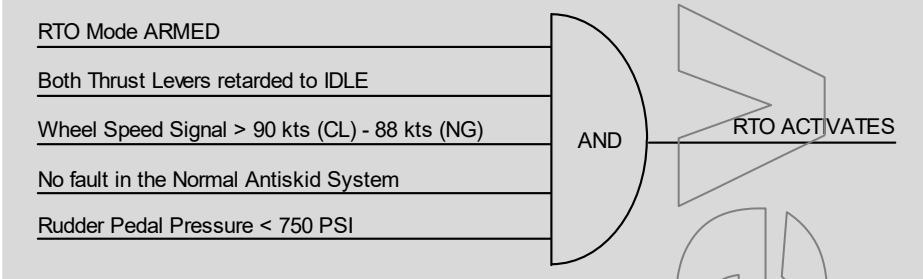
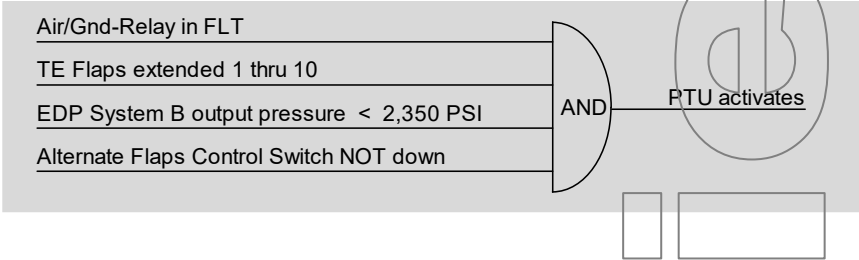
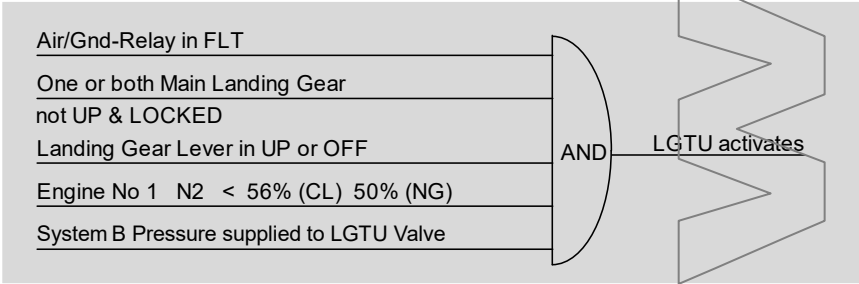

demo 4

The **B737MRG** has
many full color
drawings and diagrams

Brake System Schematic

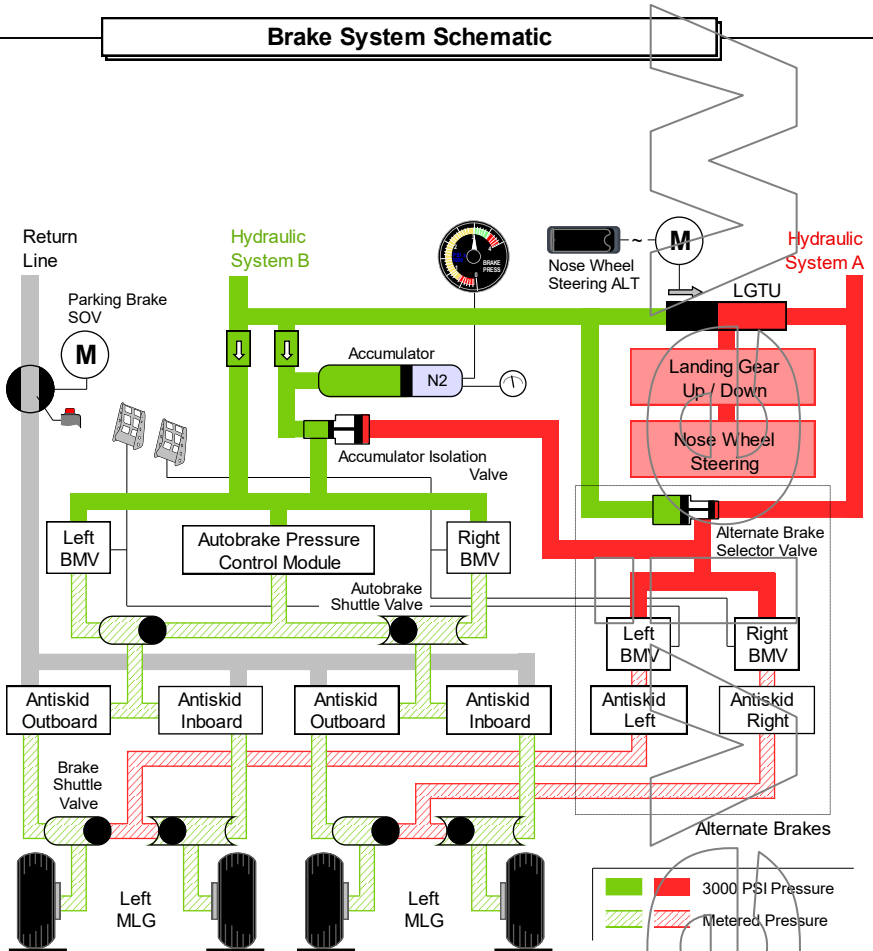

Toilet Flush Malfunction

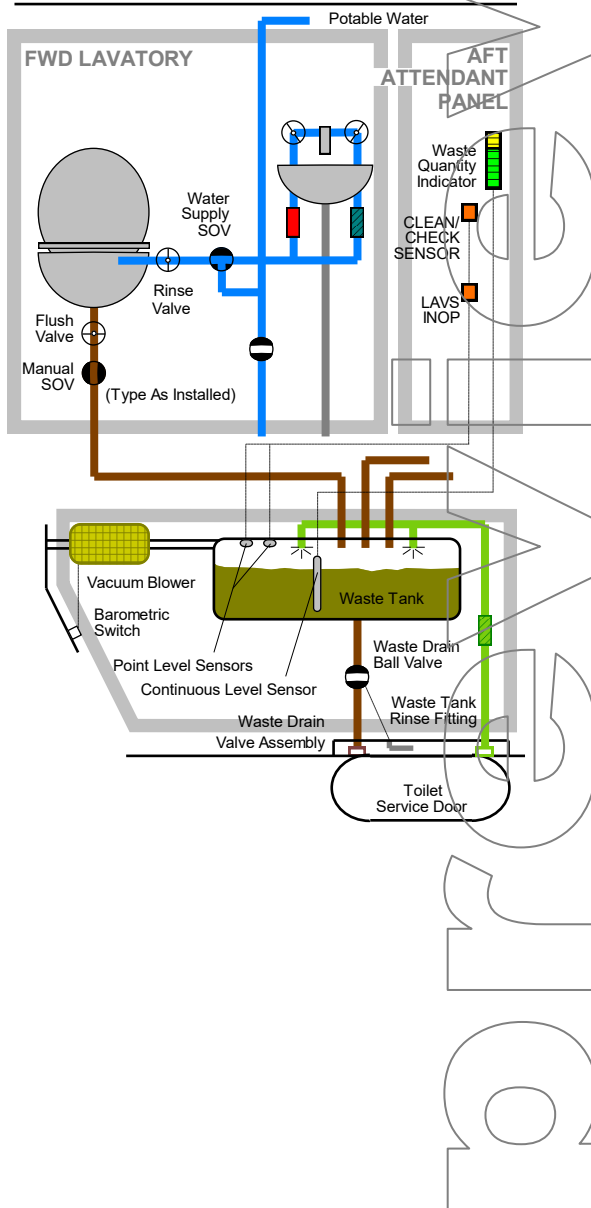

Antenna Location

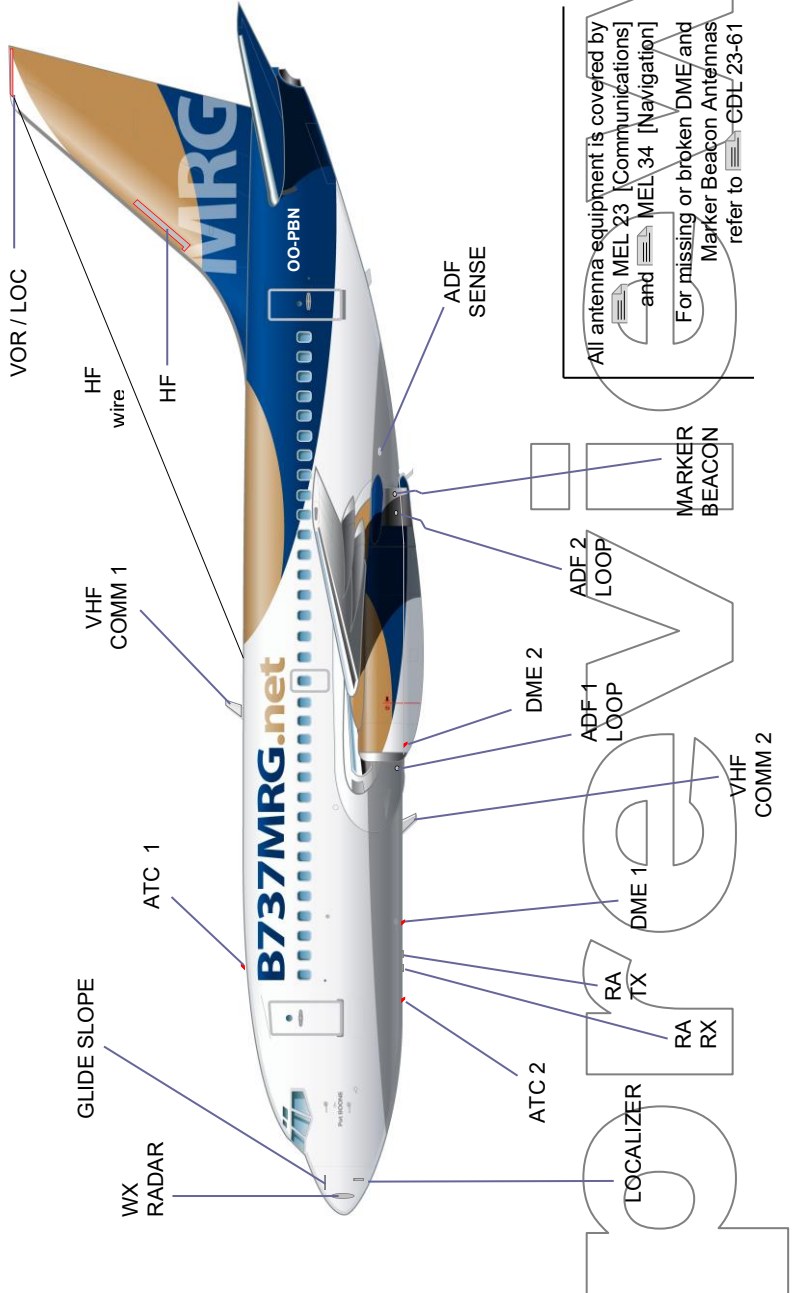

All antenna equipment is covered by MEL 23 [Communications] and MEL 34 [Navigation]. For missing or broken DME and Marker Beacon Antennas refer to GDL 23-61

demo 5

The **B737MRG** contains
all flight deck
and all circuit breaker
panels

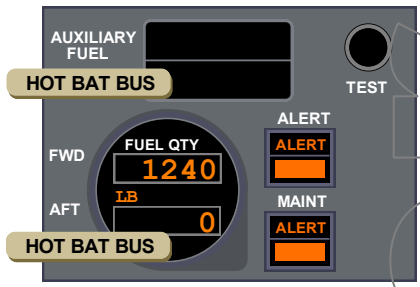
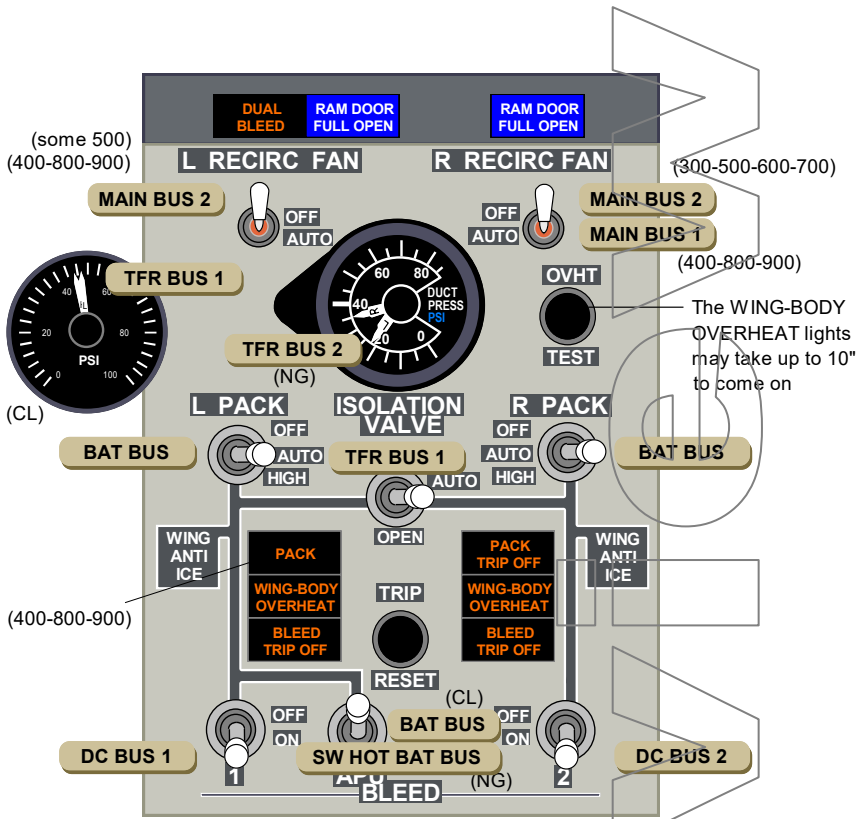

BBJ auxiliary fuel panel

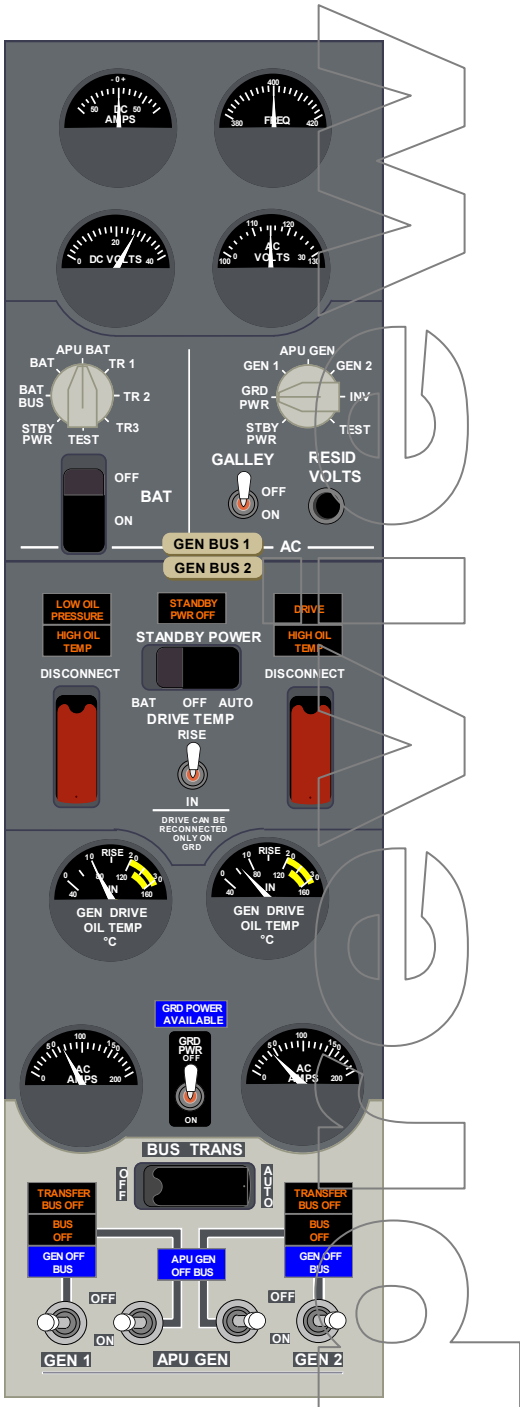





demo 6

The **B737MRG** provides
instructor training notes
how to manage non-normals

ALL FLAPS UP LANDING

 FCTM 8.x [Leading Edge or Trailing Edge Device Malfunctions]

| Section | Remarks |
|------------|-----------------------------------------------------------------------------------------------------------------------------------------------------------------------------------------------------------------------------------------------------------------------------------------------------------------------------------------------|
| Approach | Request radar vectors for 15 miles final with wide turns due to 15° bank angle limit |
| | With a published procedure turn , adjust outbound leg heading or timing due to limited bank ! |
| | Expect impression of being high on profile due to a high nose-up attitude |
| Landing | Burn off fuel to practical minimum in order to reduce landing weight |
| | No flare, positive landing. Apply forward column pressure after touchdown ! |
| | Autobrakes are not recommended, use maximum reverse thrust and gentle braking |
| | High speed tires maximum 195 kts ground speed. Verify tire condition with external inspection. |
| | Be ready to take over with nose wheel steering for directional control upon roll-out |
| | Choose RWY : - Weather forecast at ETA (= after fuel burn-off) and landing minima CAT I - Refer to  PI [Adv. Info - Non-Normal Configuration Landing Distance] - Avoid wet runway and crosswind - Verify obstacles for straight ahead go-around |
| Go-Around | Go-around with Flaps UP |
| | Limit bank angle to 15° when speed is below Flaps UP-speed |
| ATC | "PAN-PAN : Technical problem - No flaps - Landing at high speed" |
| | Request : - Weather forecast at ETA (= after fuel burn-off) - Straight ahead go-around due to limited bank - Fire brigade inspect landing gear after landing Report : - Holding time required to burn-off fuel and prepare for approach - Souls on board - Fuel upon landing - Any or no dangerous goods on board |
| Cabin Crew |  OPS - Brief the CCM in line with company procedures |
| | Refer to  MRG p. Fout! Bladwijzer niet gedefinieerd. [RISK LEVEL] for guidelines : with a long dry RWY available, a precautionary landing is suggested. |
| Passengers |  OPS - Reassure passengers in line with company guidelines |
| | Example : "Technical problem, airplane under control. Remain in holding for x time to reduce fuel. Follow Cabin Crew instructions." |

ENGINE START PROBLEMS

NO AUTOMATIC STARTER CUTOUT

Condition : Start Switch does not move back to OFF at 46% (CL) - 56% (NG) N2

➔ Manually position the Start Switch to OFF or AUTO. If the Start Valve does not close, accomplish the  NNC [START VALVE OPEN]. In this case, **do not shutdown the engine by recall**, because you will blow-up the starter !







EARLY STARTER CUTOUT

Condition : Start Switch moves back to OFF before N2 reaches 46% (CL) - 56% (NG)



An early starter cutout may result in a **HOT** or **HUNG start** !



- Start Switch fails
- Start valve  tripped :  P6-2A (CL)  P18-2B  P6-2C (NG)
- N2-indicator failure (CL) :  P6-2D  MEL 77-03 **(NOGO - Eng. No 1)**



➔ Apply  MEL 80-02 [Engine Starter Auto Cutout]

The start valve is electrically controlled, pneumatically operated and spring-loaded closed. Premature removal of the ground or APU air source may also cause an early starter cutout.

NO ENGINE ROTATION

Condition : Engine RPM remains at zero with normal Start valve OPEN-indication and normal duct pressure drop (CL) - rise (NG).



- N2 zero :
 - Mechanical failure in the starter (e.g. shaft shear) or inside the engine (N2 rotor seize up)
 - Failure of the N2 indicator / tachometer -  MEL 77-03 (CL) ▶▶ Refer to  MRG p.Fout! **Bladwijzer niet**

gedefinieerd. [Engine Indicating]

- Excessive use of bleed air (make sure both packs and wing anti-ice are switched off !)
- N1 zero :
 - Mechanical failure in the engine (N1 rotor seize up)
 - Failure of the N1 indicator / tachometer -  MEL 77-02

FUEL FLOW ZERO or LOW

Condition : Fuel flow shows zero or below normal values (0.30 kg / 0.65 lbs per hour) when start lever is raised to IDLE.



- FCU fails :  None → **NOGO**
- Fuel SOV closed : Verify  P6-3D (CL) -  P6-3B  P6-3C (NG)

LOSS OF BOTH ENGINE DRIVEN GENERATORS

 FCTM 8.x [Approach and Landing on Standby Power]

(CL)



Do NOT connect GEN on bus by recall !

A number of systems must first be switched OFF to avoid current peak

Do NOT abort takeoff

- Antiskid is INOP (V1 for antiskid INOP is roughly 20 kts lower)
- RTO is INOP
- No immediate awareness of aircraft speed versus V1
- No automatic extension of speed brakes



- Switch on cockpit dome light bright as soon as practical
- Monitor standby ASI for actual speed versus V1
- The standby horizon displays a flag due to power loss, however instrument is reliable for rotation (gyro spooldown takes a while)

Once airborne

- Captain is PF
- Electrical trim INOP
- Maintain takeoff flaps setting (Flap Position Indicator INOP)
- Level-off at minimum safe altitude since airplane is unpressurized !
(caution : there is no aural altitude alert to level-off !)
- Call ATC - "PAN-PAN" (3x) - Request radar vectors
- Fly raw navigation (full rose) due to possible IRS drift
- Autothrottle is disconnected !
- Maintain speed between speed-tape yellow bars on EADI



Once airborne, STBY AC BUS and STBY DC BUS automatically switch to their back-up source. The STANDBY PWR OFF amber light should not be illuminated !



APU start and on bus

- connect preferable on GEN BUS No 2 to supply TR3
- if unable to connect the APU to GEN BUS No 2, connect it to GEN BUS No 1
- if the loss of both generators was caused by an engine failure, connect the APU to the bus of the operating engine in order to recover both hydraulic systems!
- only one APU start attempt is recommended to preserve battery life. A second start attempt could be considered below 25,000 feet, as the probability of a successful start increases. (especially Garret APU)



If unable to recover any GEN BUS :

- "MAYDAY" (3x)
- Land within 30 minutes (45 min with APU BAT installed)
- Above FL300 thrust deterioration or engine flameout may occur

(continued...)

demo 7

The **B737MRG** contains contains basic maintenance tips & tricks to investigate or reset a failure



On GND

Refer to  MEL 24-16 [ELEC light] for the amber light itself. The ELEC amber light illuminated is a **NOGO**.

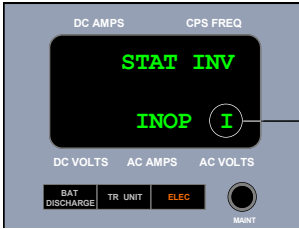

Additional information on the electrical fault can be obtained from the LAD on the electrical panel as follows :

(**I** indicates the fault is intermittent and not set at this time)

Select **both AC and DC Meter Selectors to TEST** and temporarily push the MAINT switch.

The BITE will first illuminate all segments of the LAD (takes about 15 seconds) and then show the fault information. To bypass the BITE display test, push the MAINT switch just after test begins. If there are no faults, the message **NO FAULTS STORED** will appear.

When pushing the MAINT switch again, the next fault will be displayed, if any. Continue until all faults have been displayed and **HOLD BUTTON CLEAR FAULTS** is announced.



Press the MAINT switch for approx. 6 seconds (until **FAULTS CLEARED** appears) to reset all faults. Except for GEN1-2 FAULT, the fault cannot be cleared by pressing the MAINT switch, when the fault still exists. In this case return to gate.



HYDRAULIC EMDP DOES NOT ENGAGE

ENGINE DRIVEN PUMP DOES NOT ENGAGE (with engine running)



- the depressurization solenoid valve remains powered while it should not be fed when the EDP switch is selected ON. This failure can be confirmed by removing electrical power from the solenoid : Pump Depress Valve  P6-2AB
- the hydraulic pump is inoperative or the pump SOV is inadvertently closed : (the latter would be the case with the associated Engine Fire Switch not properly stowed, but then the engine would not be running...)



Dispatch as per  MEL 29-10 [System A Pumps]
 MEL 29-02 [System B Pumps]

Your company  SOP may require the **EDP** for CAT II-III. Verify the Lower Landing Minimum Requirements Table.

ENGINE DRIVEN PUMP DOES NOT DISENGAGE (with engine not running)



- the pressure module check valve may be inoperative



The pressure module check valve prevents hydraulic backflow through the pressure filter in case EDP output pressure is low. It also isolates the EDP pressure switch. If the check valve fails, the EDP pressure switch senses system pressure. Check valve failure is confirmed if the LOW PRESSURE amber light of the EDP illuminates by turning off the associated EMDP.

ELECTRIC MOTOR PUMP DOES NOT ENGAGE (when selected ON)



- the opposite Generator Bus (CL) - Transfer Bus (NG) is not powered
- the EMDP  has tripped : (CL) P6-2A P6-11C P6-12C (NG) P91CF P92CF
- the pump is in "ground fault" or overcurrent :



To reset the "ground fault" :

(cont'd)

demo 8

The **B737MRG** alerts for compound failures

BLEED TRIP OFF



SUBSEQUENT FAILURE(S)

PACK TRIP OFF / PACK opposite side



Pressurization is lost



Position the failed Pack Switch to OFF, causing the Isolation Valve to open. Use the remaining pack with the opposite engine.

ENGINE FAILURE or BLEED TRIP OFF opposite side



- Pressurization is lost
- Main Outflow Valve will drive to fully closed position
- Cabin pressure altitude will climb at 1,000 to 2,000 fpm
- Advise ATC for immediate descent
- Descend in the airway to single engine service altitude or 17,000 feet where the APU may be used as an alternate air source
- Select Engine No 1 Bleed Air to OFF (to extinguish DUAL BLEED amber light)

WING-BODY OVERHEAT opposite side



The checklist calls to switch off the affected engine bleed air. However, since this will result in a loss of both packs and thus loss of pressurization, consider to :

- Retard thrust on the respective engine
- Advise ATC for immediate descent
- Accomplish the NNC [WING-BODY OVERHEAT]
- Left WING-BODY OVERHEAT :
 - Descend to 10,000 feet (or minimum safe altitude if higher)
 - Continue unpressurized to destination or diversion field (trip fuel at 10,000 feet is approximately 10 x distance)
- Right WING-BODY OVERHEAT :
 - Descend to FL 170 in airway
 - Use the APU as an alternate air source



If this event occurs at low altitude, you can indeed switch-off the affected engine bleed air immediately. The cabin pressure altitude will climb at 1,000 to 2,000 fpm, and it should not reach 10,000 feet before the airplane is at FL100.

WING ANTI-ICE VALVE OPEN opposite side



Checklist calls for switching off the affected engine bleed air and pack. However, since this will result in a loss of pressurization, consider to :

(cont'd)



demo 9

The **B737MRG** redirects to
DDG-MEL, QRH, FCOM, FCTM
EASA, FAA, etc



PASSENGER OXYGEN ON

 MEL 35-5 [Passenger Oxygen System] The aircraft can be dispatched at FL250 with passengers on board with the passengers oxygen system INOP. Flight crew oxygen, however, must always meet minimum dispatch requirements for smoke protection in flight.

DISPATCH REQUIREMENTS

-  JAR 8.8.1 [Oxygen Requirements]
-  FAR 91.211 [Supplemental Oxygen]

IN FLIGHT OXYGEN REQUIREMENTS

 JAR 8.8.1 -  JAR OPS-1.770 -  FAR 121.329/333 - Supplemental oxygen for emergency descent and first aid on turbine engine airplanes with pressurized cabin :

| | | |
|-------|-----------------------------|---------------------------|
| FL150 | Flight Crew Oxygen required | Passenger Oxygen required |
| FL140 | | |
| FL130 | | |
| FL100 | > 30 min | 10% pass. (*) |
| SL | | |

(*) For aircraft certification oxygen supply is required between FL100 and FL140 for 10% of the passenger capacity. Since the passenger oxygen system cannot comply with this requirement, the level-off altitude in the  NNC [Emergency Descent] has been lowered to 10,000 feet while 14,000 feet for the B737-200.

 JAR/FAR 25.1447 requires that the flight crew oxygen dispensing unit can be placed from the stowed position on the face with one hand within five seconds.

OXYGEN BOTTLE REFILL OR REPLACEMENT

Special safety precautions apply when replenishing or replacing the crew oxygen bottle, including ;

demo 10

The **B737MRG** contains
multiple tables
with valuable numbers

HYDRAULIC SYSTEM

| Sys | (CL) | | | (NG) | | Pressure | Status |
|-------------|------|------------|------|-------|-------|---------------------------------------|---------------------------------------------------------------------|
| | USG | Indication | | USG | Ind. | | |
| A | | | | 6.80 | 106% | | Max. capacity - Overfill |
| | 4.80 | F | 100% | 5.70 | 100% | 3000 PSI | Full |
| | 4.20 | RFL | 88% | 4.70 | 76% | 3000 PSI | Refill limit |
| | 4.00 | | 83% | 4.00 | 70% | 3000 PSI | Gear Up - In FLT |
| | 1.80 | <1/4 | 22% | 2.30 | 20% | 3000 PSI | Leak in EDP System OK |
| | 1.00 | 0 | 0% | 1.00 | 0% | > 0 PSI | Zero QTY indication |
| | 0.00 | | | 0.00 | | 0 PSI | Leak in EMDP or lines Loss of System A |
| B | | | | 10.70 | 106% | | Max. Capacity - Overfill |
| | 7.20 | F | 100% | 8.20 | 100% | | Full |
| | 6.40 | RFL | 88% | 6.90 | 76% | 3000 PSI | Refill Limit |
| | 4.95 | >1/2 | 64% | 6.60 | 72% | 3000 PSI | Leak in STBY System Loss of STBY System |
| | 3.50 | <1/2 | 40% | 1.30 | 0% | 3000 PSI (CL) | Leak in EDP System OK (CL) |
| | 1.30 | >0 | 5% | | | > 0 PSI | Leak in EMDP or lines Loss of System B but sufficient for PTU |
| | 1.00 | 0 | 0% | | | > 0 PSI | Zero QTY indication |
| 0.00 | | | 0.00 | | 0 PSI | Leak in PTU Loss of System B + PTU | |
| STBY | 2.80 | - | - | 3.60 | - | | |
| | 1.40 | LOW QTY | | 1.80 | LOW | | Loss of STBY System |

demo 11

The **B737MRG** contains
all circuit breakers
and electrical power sources

ELECTRICAL POWER SOURCE / BUS

NG

TRANSFER BUS 1 - 115 VAC

Air Cond Isolation Valve
APU SCU
CDU 1 (*)
Engine 1 EEC
Equip Cool Supply Fan Power Altn
Galley Bus C-D
GPWS
Hyd Sys EMDP 1 Sys B
Radio Navigation DME 1 (*)
Radio Navigation Radio Altm 1
TCAS
TRU 1
Vacuum Waste Blower
Yaw Damper Indicator

XFR BUS 1 SECT 1 - 28 VAC

Lights - Pass. Cabin Reading Left
Yaw Damper AC

XFR BUS 1 SECT 1 - 115 VAC

AFCS Stabilizer Trim
AFCS Sys A Mach Trim AC
AFCS Sys A Sensor Excitation AC
ATC 1 (*)
Communications HF 1
Data Loader
Engine Anti-Ice Valve
Engine 1 Altn PWR Chan A - B
Engine 1 Ignition Left
Flight Recorder AC
FMCS Computer 1 (*)
FMCS MCDU 1 (*)
Heaters Alpha Vane Left
Heaters Captain Pitot (*)
Heaters Elev Pitot Left
Heaters Temp Probe
Lights - Ext. Anti Collision Red
Lights - Ext. Anti Collision White
Lights - Ext. Landing Left Fixed
Lights - Ext. Landing Right Retractable
Window Heat Control Left Front AC
Window Heat Control Right Side AC
Wing Anti-Ice Valves

TRANSFER BUS 2 - 115 VAC

ATC 2 (*)
CDU 2
Engine 2 EEC

1. Airplane General, Emergency Equipment, Doors, Windows

| | | |
|------------------------|-------|-----------|
| Air Stair | P18-1 | C, D |
| Door Lock, Warning | P6-3 | C1, A2 |
| Galley Aft | P6-12 | C7-9 |
| Galley Forward | P6-11 | C7-9 |
| Lavatory Flush Motors | P18-4 | B3,B6,C6 |
| Lavatory Water Heaters | P18-4 | A5-7 |
| Lights | | |
| Anti Collision | P18-3 | C15-16 |
| Landing | P18-3 | A13-16 |
| Taxi Nose Gear | P18-3 | D14 |
| Position | P18-3 | B15,B16 |
| runway Turnoff | P18-3 | D15-16 |
| Service | P18-3 | E14-16 |
| | | F14-16 |
| Wing | P18-3 | B13 |
| AFCS Flood | P6-3 | E12,E14 |
| Control Cabin | P6-3 | A9-15 |
| Emergency Exit | P18-3 | A12 |
| Entry (dim) | P6-5 | B6 |
| Lav Dome-Mirror | P18-3 | F10-11 |
| Lav Mirror Ext Power | P6-3 | D1 |
| Master Dim Bus Ind | P6-3 | B13-B15 |
| | | C13-C15 |
| | | D13-15 |
| No Smoke/Seat Belts | P18-3 | A9-10 |
| Overhead Panel | P6-3 | E9,E1 |
| | | F9-14 |
| Instrument Panel | P6-3 | B11-B12 |
| | | C9,C11-12 |
| Pass. Signs Control | P18-3 | A11 |
| Galley | P18-3 | B8,C6 |
| | | D6,E6,F12 |
| Pass. Window | P18-3 | B6-7 |
| Oxygen System | P18-3 | F6-9 |
| Service Outlets | P6-3 | E1,F1 |
| Vacuum/Cleaner Recep | P18-4 | C1-2 |
| Water Quantity Ind | P18-4 | A2 |

2 Air Systems

| | | |
|-------------------------|-------|---------|
| Bleed Air Valves | P6-4 | B1-3 |
| Cabin Air Recirculation | P6-4 | E5 |
| Equipment Cooling | P18-3 | A18,B18 |
| | | C18,D18 |
| | | E18 |
| Fan Control Supply | P18-3 | F17-18 |
| Forward Outflow Valve | P6-4 | C5 |

demo 12

The **B737MRG** provides
simple flow charts
to analyze a non-normal

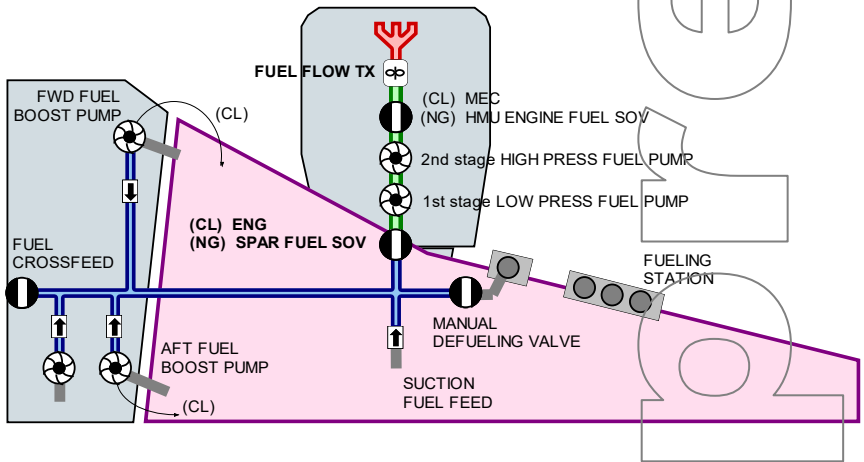
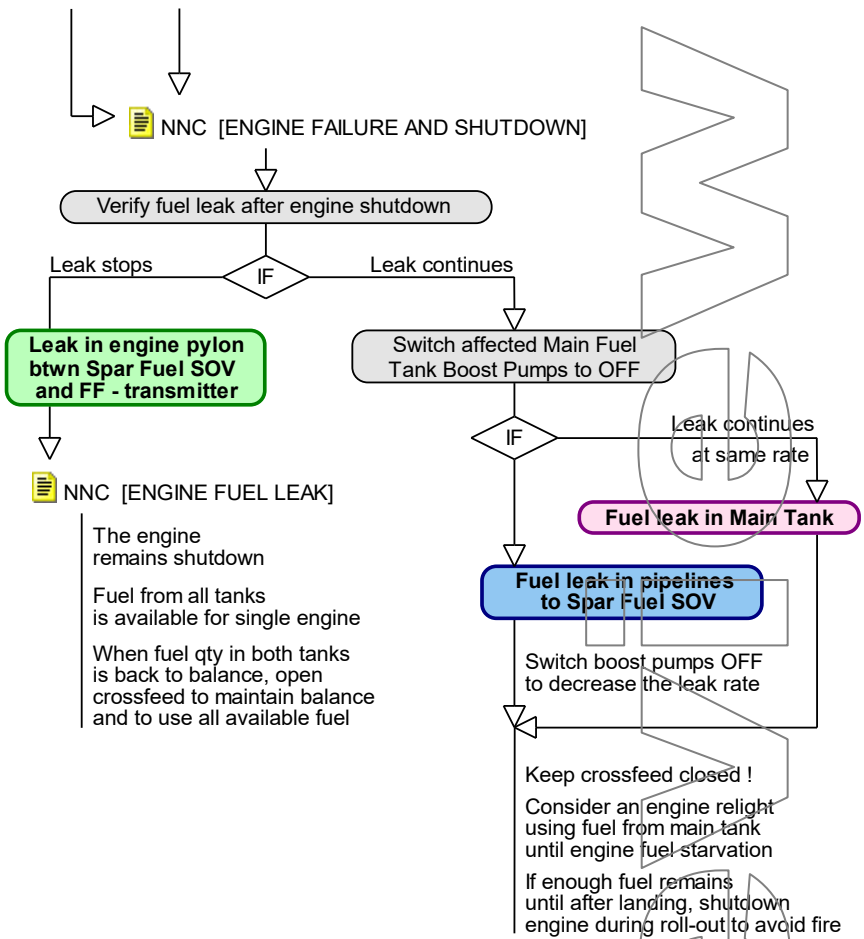

demo 13

The **B737MRG** contains
useful rules of thumb

AUTO FAIL UNSCHEDULED PRESSURIZATION CHANGE

CPCS



Rule of Thumb to crosscheck proper pressurization of the cabin during climb :

At FL 100 the needles should point approximately 1 and 4

(valid for cruising levels > FL250)



Rule of Thumb to verify whether cabin pressure can follow airplane descent :

CABIN ALT / 100 = NAUTICAL MILES REQUIRED

e.g. The cabin altitude pressure shows 4,000 feet, then the controller requires circa 40 NM to descend to sea level

If distance to destination is 40 NM or more, remain in Auto Mode. If track miles to destination is less than 40 NM, select Standby Mode and increase rate of descent.

If destination elevation is well above SL, subtract Land ALT from the Cabin ALT :

(CABIN ALT - LAND ALT) / 100 = NAUTICAL MILES REQUIRED

e.g. The cabin altitude pressure shows 4,000 feet and destination elevation is 1,500 feet, then the controller requires circa 25 NM to descend to airport elevation.

RULES OF THUMB

Memorize this 1/60 table (speed in NM / min)

| speed (kt) | 120 | 150 | 180 | 210 | 240 | 270 | 300 | 330 | 360 |
|--------------|-----|-----|-----|-----|-----|-----|-----|-----|-----|
| speed number | 2 | 2½ | 3 | 3½ | 4 | 4½ | 5 | 5½ | 6 |

1) SAT out of TAT



$$\text{SAT } (^\circ\text{C}) = \text{TAT } (^\circ\text{C}) - 3 \times \text{Mach}$$

$$\text{TAT} = -17^\circ\text{C} \text{ Mach } 0.64$$

$$\text{SAT} = -17 - (3 \times 6) = -17 - 18 = -35^\circ\text{C}$$

2) SAT out of TAT for higher Mach and lower Temp



$$\text{SAT } (^\circ\text{C}) = \text{TAT } (^\circ\text{C}) - ((100 \times \text{Mach}) - 50)$$

$$\text{TAT} = -31^\circ\text{C} \text{ Mach } 0.74 \rightarrow \text{You have 24 above M } 0.50$$

$$\text{SAT} = -31 - 24 = -55^\circ\text{C}$$

3) Level Off procedure if R/C \leq 1,000 feet/min (also for descent R/D)



$$\Delta \text{ feet} = \frac{\text{R/C (feet/min)}}{10}$$

$$\text{Climbing to FL } 210 \text{ R/C} = 2,000 \text{ feet/min}$$

$$\Delta \text{ feet} = 200 \text{ feet} \rightarrow \text{start level off at } 20,800 \text{ feet}$$

4) Level Off procedure if R/C $>$ 1,000 feet/min (also for descent R/D)



$$\Delta \text{ feet} = 2 \times \frac{\text{R/C (feet/min)}}{10}$$

$$\text{Climbing to FL } 300 \text{ R/C} = 2,500 \text{ feet/min}$$

$$\Delta \text{ feet} = 500 \text{ feet} \rightarrow \text{start level off at } 29,500 \text{ feet}$$

5) Cruise Flight Level computation



$$\text{Cruise FL} = \text{Trip Distance (NM)}$$

$$\text{EBBR-EBOS} = 60 \text{ NM}$$

$$\text{Optimum is FL } 60$$

demo 14

The **B737MRG** contains
30 years of line experience
to help you manage issues



FAM



Your airline may have special procedures for bomb search and handling

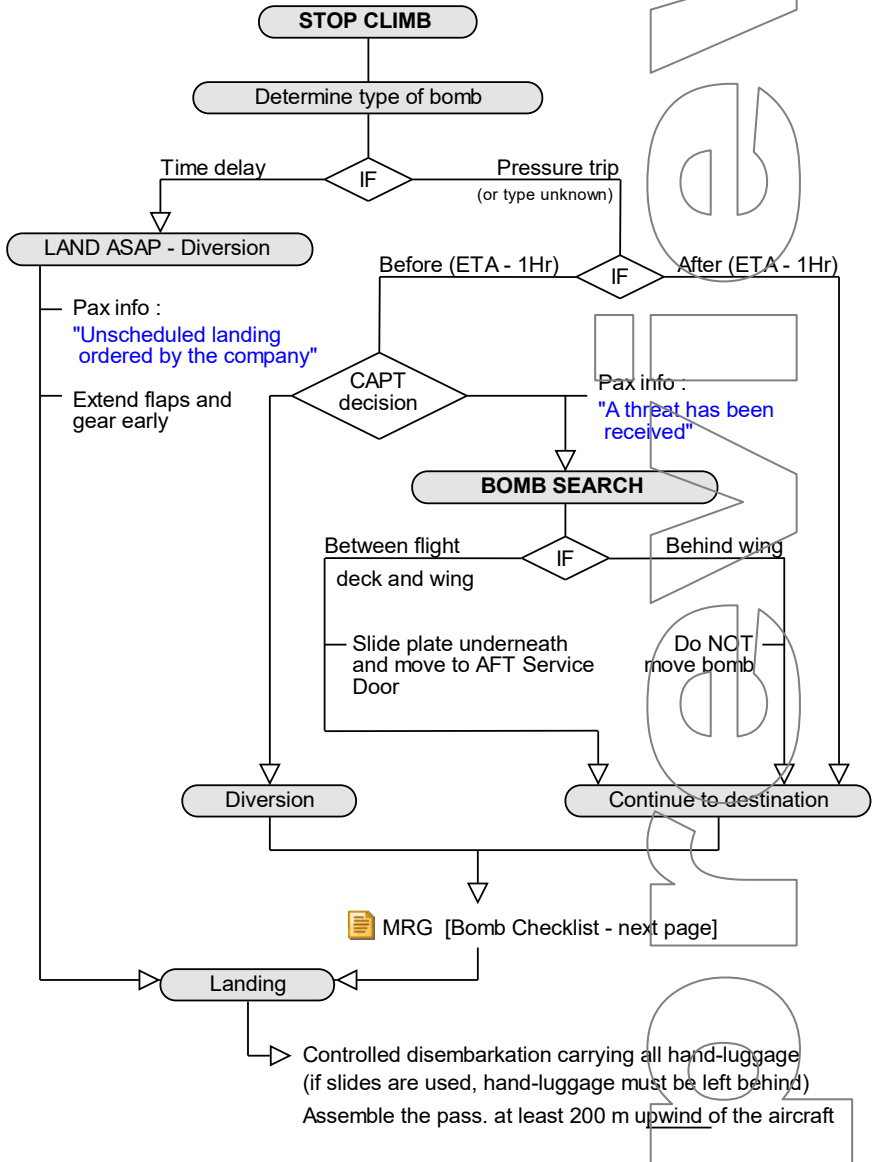

JAR 10.2.4



FIRE DRILL

Refer to  FAM 9.x [Fire Fighting] for additional info
information  MRG p.**Fout! Bladwijzer niet gedefinieerd.** [SMOKE] for additional information

FIRE / SMOKE IN OVERHEAD STORAGE BIN



- move passengers away
- remove seat covers, life vests and other materials
- extinguish the fire / smoke
- remove objects from the adjacent bins
- remove the fire / smoke source from the bin



Remove all flammable items in the vicinity that might catch fire, such as passenger hand-luggage, cushions, news papers, etc. including seat covers and life vests.



Push down all seat-backs for about 3 rows in vicinity and cover them with wet blankets. These blankets will not only protect the seats, but will also catch, muffle up and dampen any burning item falling out of the bin.

(cont'd)

LASER ILLUMINATION

Although not inherently dangerous, continuous laser illumination can cause distraction, discomfort and injury to the eyes, including glare, temporary blindness and after-image.



- **Do not stare at the laser in an attempt to locate its position**
- Advise ATC and **request a turn away from the laser source**
- Hand-over flight controls to the non-exposed pilot and/or engage the autopilot
- **Do not rub your eyes**, this will make it worse and may cause corneal abrasion
- After flight, file a report on the event and seek medical help if necessary

Sunglasses and flight deck sun blinds do not provide protection against laser illumination !

end

